



DZBX-2MT ZINC BLAST



FEATURES

- 
No damage at product surface
 The machine is specially designed for blasting items that cannot be treated with tumbling blast application. DZB produces superior projection for aluminum die-casting products.
- 
Safety blasting with zinc shot
 DZB is designed to use with zinc shot that can prevent explosion when involving with aluminum fine dust.
- 
Compact size
 Compact size of the machine makes an installation easier. Equipped with 2-station, the machine allows operator to load /unload the products in the front while blasting on process at the back.



The Double-Station Design Promotes Greater Efficiency
by allowing products to be loaded and unloaded during blasting treatments.

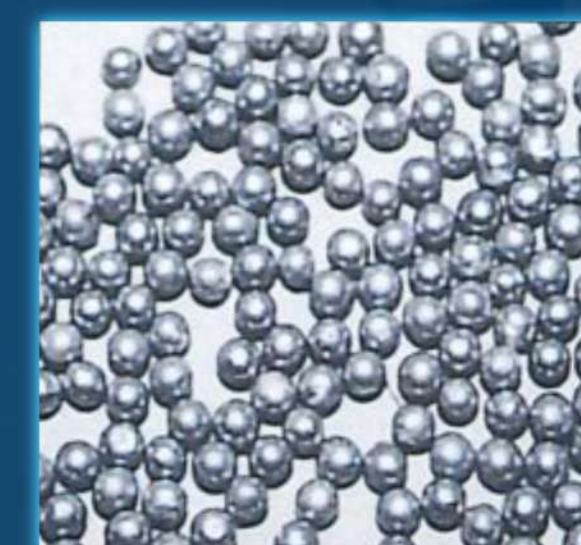

Blasting media for die-cast products
Our advanced shot is most suitable for die-cast products. Safe work environment. High deburring capacity and beautiful white gloss finish.



Before

After



sinto SURFACE TECMART
for the Better

APPLICATIONS



Transmission Case



Engine Parts



Automotive Parts



HDD Case



Product Biting and Product Residue "zero"
In the processing of small, thin, round and thin products such as screws and springs, quality improvement is achieved with zero product bite and product residue.



DZBX-2MT ZINC BLAST DIMENSION



sinto SURFACE TECMART
for the Better

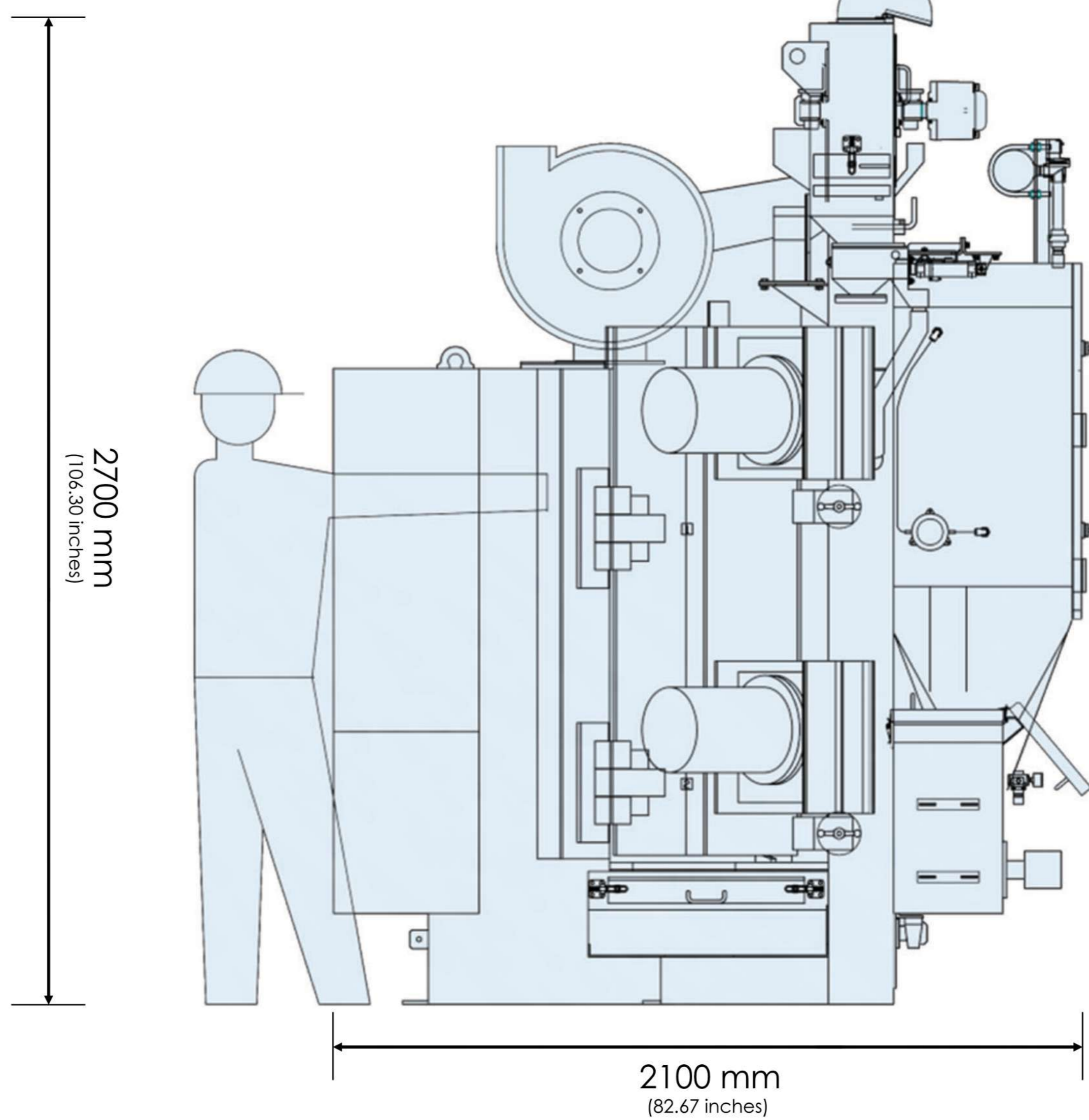
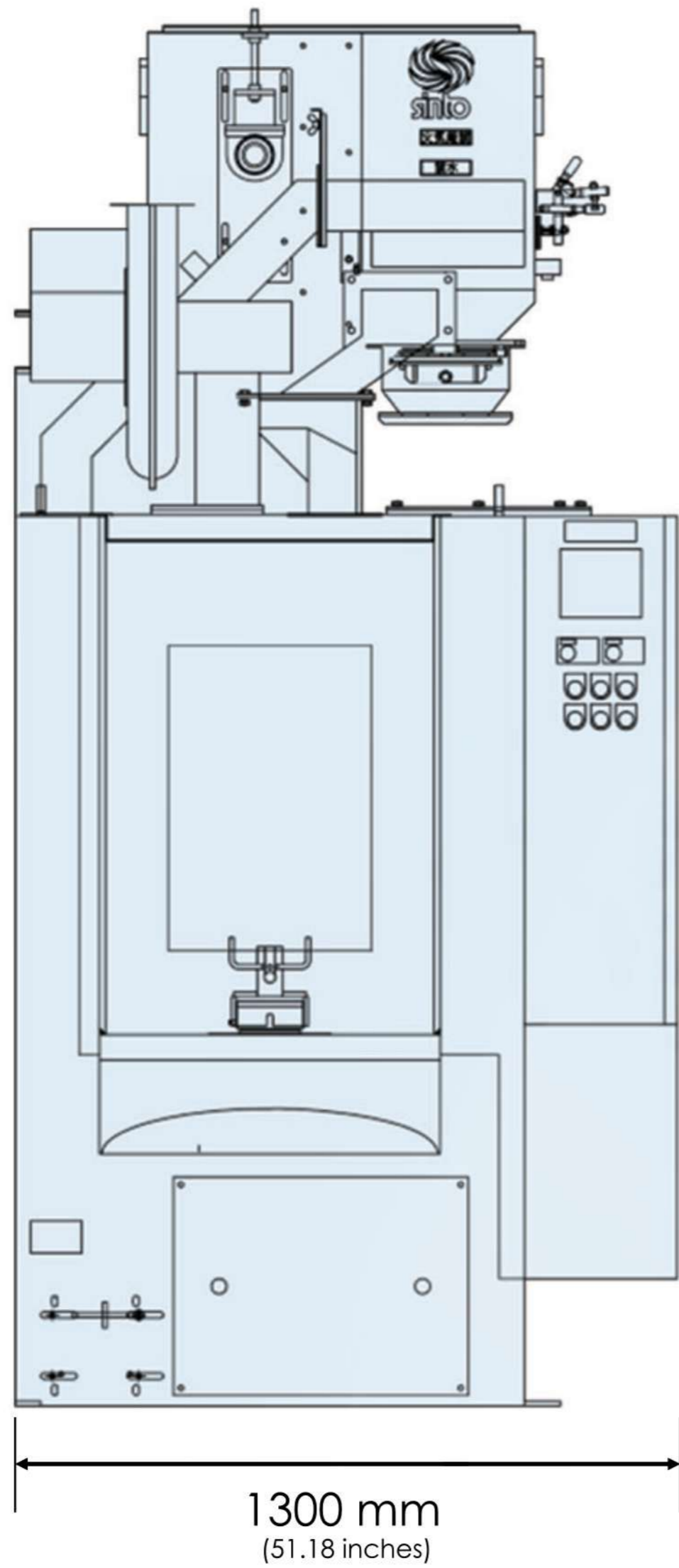
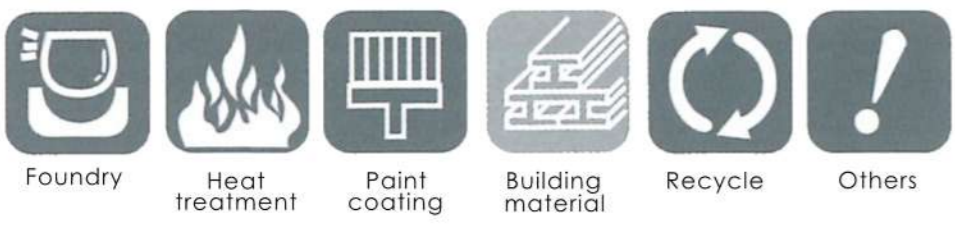

SPECIFICATION DZBX-2MT

Capacity	Blasting area per jig (mm)	Ø400 x 600H (Max)
	Weight of work piece (including jig)	20kg / jig (Max)
Impeller	Motor capacity (kW)	5.5kW x 4P (2 units)
Hanger	Number of hanger	2
Dust collector	Air volumn (Nm3/min)	15

* To improve quality of our product, changes of specification may apply without prior notice

Suitable for deburring thin-walled die-cast products without warping them

For deburring die-cast products

3-in-One SOLUTION

IN ASSOCIATION WITH SIAMBRATOR

We are determined to meet our customers' most satisfaction. That is the reason behind our 3-in-1 business solution by offering cutting edge technology and equipment, medias and abrasives, and after-service maintenance.

Shot
blasting

Surface
roughening

Deburring

Processing
Equipment

Blasting
media

Support
for Stable
Operation



THAI SINTOKOGIO CO.,LTD.
SINTOKOGIO GROUP
Rojana Industrial Park 2
44 Moo 4, Banchang, U-Thai Ayutthaya 13210 THAILAND
TEL: +66 (0) 35-200-710-8 FAX: +66 (0) 35-200-719
www.thaisinto.co.th Line Official : Thai Sinto



ISO 9001:2015 ISO 14001:2015 CERTIFIED