



sinto

New Harmony >> New Solutions™

www.thaisinto.co.th

# MY-40E

## 1. Heavy duty

MY-40E can handle Maximum 1000kgs of workpiece. Its turntable eases operator to blast around edges and corners of workpiece.

## 2. Variety of application

MY-40E can be applied with wide range of abrasives in turn providing a variety of blasting application to many different kind of product surface.

## 3. Compact size

Equipped with dust collector as single unit machine in return saving installation space.

## 4. Eco-friendly

Requires less power consumption (Electricity 0.9kW and air 0.5Nm<sup>3</sup>/min.)



sinto SURFACE TECMART  
*for the Better*

## APPLICATIONS

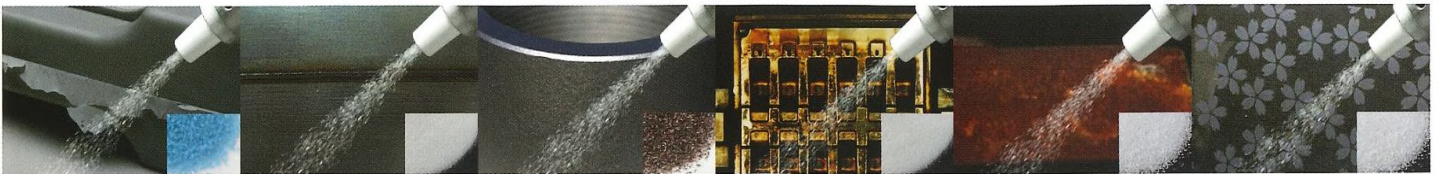

## 3 魅一体

### 3-IN-1 SOLUTION (IN ASSOCIATION WITH SIAMBRATOR)

We are determined to meet our customers' most satisfaction. That is the reason behind our 3-in-1 business solution by offering cutting edge technology and equipment, medias and abrasives, and after-service maintenance.



THAI SINTOKOGIO CO.,LTD.  
SINTOKOGIO GROUP  
Rojana Industrial Park 2  
44 Moo 4, Banchang, U-Thai Ayutthaya 13210 THAILAND  
TEL: +66 (0) 35-200-710-8 FAX: +66 (0) 35-200-719  
www.thaisinto.co.th Line Official : Thai Sinto



ISO 9001:2015 ISO 14001:2015 CERTIFIED  
Version 2022(01)

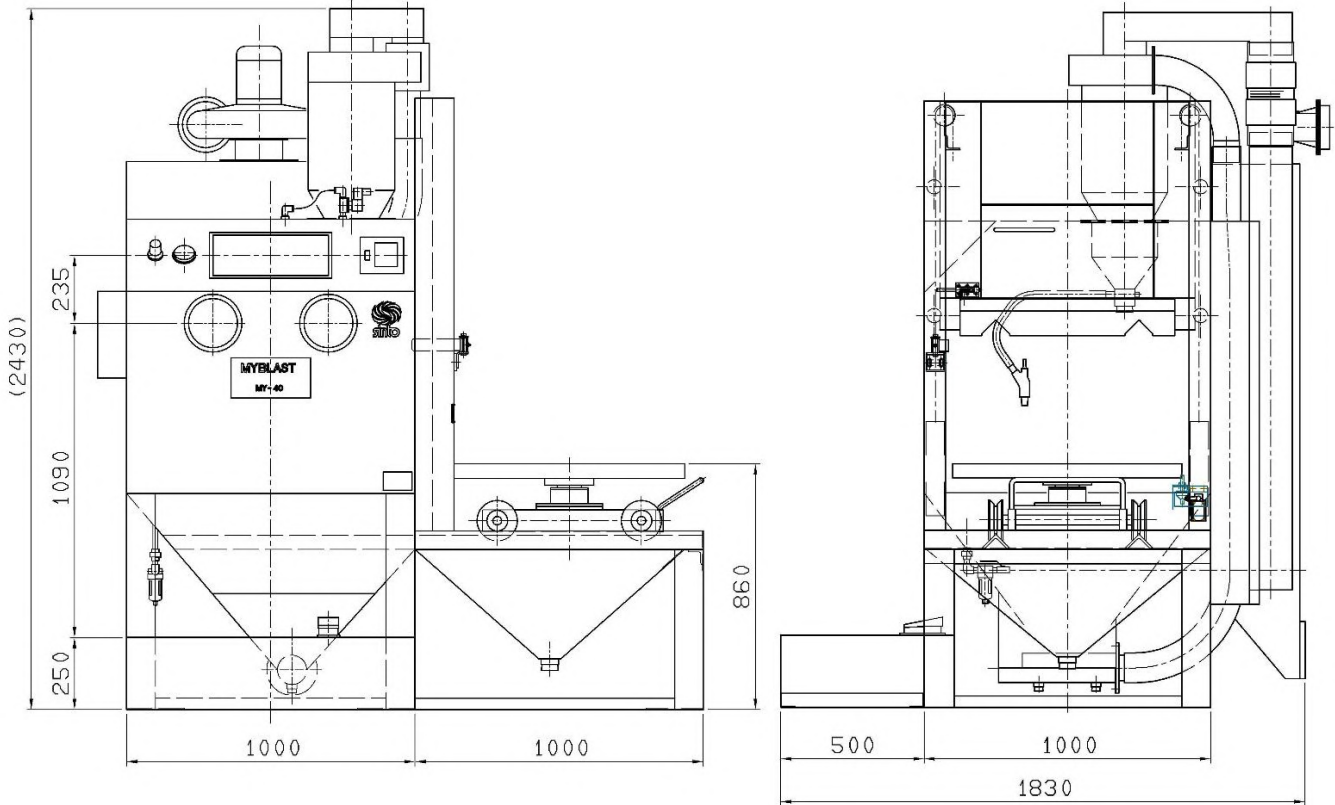

## SPECIFICATION

Blasting method	Gravity type / Nozzle thread Dia 8.0mm (ceramic)
Cabinet	Steel plate construction welded structure Glove light 1 lamp screen (Foot Switch)
Door	Workpiece passing opening 850 x 450(H)mm with close Limit Switch
Abrasive circulation	Pneumatic transfer (Separation by cyclone)
Abrasive hopper	Capacity : 6 Liters
Turn-table	Table thread Dia800mm / Load: 1000kgs (center load) / Manual rotation
Dust collector	Turbo fan (Dust removal by bag filter) Filter cleaning by manual shaking (Dust removal by rubber plug)
General information	Power consumption : 0.9kW (380V/50Hz) Air consumption : 0.5Nm <sup>3</sup> /min (at 0.5MPa nozzle 1 piece) Machine weight : 900 Kgs

\* To improve quality of our product, changes of specification may apply without prior notice



圧縮空気の方で投射材をノズルから  
投射する方式です。  
局所的な処理に適しています。

Superior blasting

Variety application

Ease of use

### Why Air Blast?

Unlike wheel blast, Air blasting application can apply to wider range of products and their materials. Abrasives are projected through air nozzle by pressurized air. Single piece of blasting or batch can be conducted. Even spot blasting with proper masking for peening can be done with use of air blast.

### What are abrasives for Air Blast?

Wide range of abrasive can be used such as steel shot and steel grit, stainless shot, alumina ball, glass beads, etc.



**THAI SINTOKOGIO CO.,LTD.**  
SINTOKOGIO GROUP  
Rojana Industrial Park 2  
44 Moo 4, Banchang, U-Thai Ayutthaya 13210 THAILAND  
TEL: +66 (0) 35-200-710-8 FAX: +66 (0) 35-200-719  
www.thaisinto.co.th Line Official : Thai Sinto



ISO 9001:2015 ISO 14001:2015 CERTIFIED

Version 2022(01)